

SPECIFICATION AND DATA

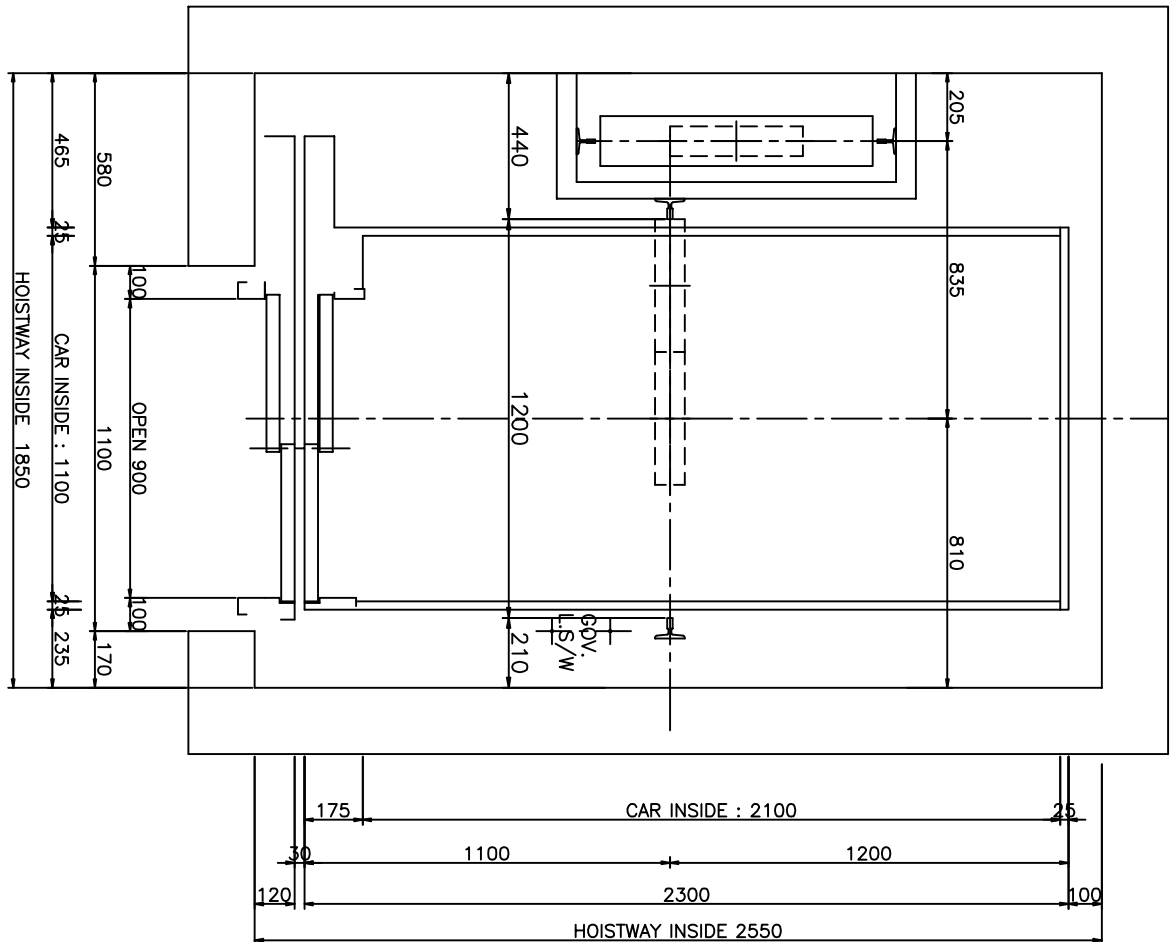

PROJECT NAME	ZK in 64 kvortol	
ELEVATOR NO.	NO. 1~6	
TYPE OF ELEVATOR	PASSENGER (EMERGENCY)	
CAPACITY	1000 kg	
RATED SPEED	1.0 M/Sec	
CONTROL	AC-VVVF	
OPERATION	SIMPLEX SELECTIVE COLLECTIVE AUTOMATIC	
ENT. / FLOOR	8 ENT. / 8 FLOOR	
FLOOR MARK	1.3~9 FLS	
TRAVEL	24000 mm	
CAR INSIDE	WIDTH 1100	DEPTH 2100 HEIGHT 2100
ENTRANCE	WIDTH 900	HEIGHT 2000
LANDING DOOR	2 PANEL SIDE OPENING	
WIRE ROPE	φ10 8XS(19) 5 NOS.	
CAR FLOORING	DECO TILE	
CAR RAIL	8 kg/m	
CWT RAIL	3U kg/m	
CAR BUFFER	OIL BUFFER	
CWT BUFFER	OIL BUFFER	
MOTOR CAPACITY	6.2 Kw	
POWER SUPPLY	MAIN	3 PHASE 380 VOLT 50 HZ
	LIGHT	1 PHASE 220 VOLT 50 HZ

HOISTWAY INSIDE	
W	1850 mm
D	2550 mm
PIT	1400 mm
OH	4800 mm

TITLE	HOISTWAY PLAN	
DRAWING NO	SE 4173/78 - E01	REV MARK

APPROVED

Name & Sign: _____

Date: _____

REV MARK	DATE	REVISED BY	CONTENTS
REVISIONS			
3RD ANGLE PROJECTION	SCALE	UNITS	DATE
	N	M/M	2012.04.02
DRAWN BY	DESIGNED BY	CHECKED BY	APPROVED BY
S.M Park	S.M Park	T.H. Hwang	T.H. Hwang
ECLIPSE		180 8001 180 14001	
BUILDING NAME	ZK in 64 kvortol		
LOCATION			

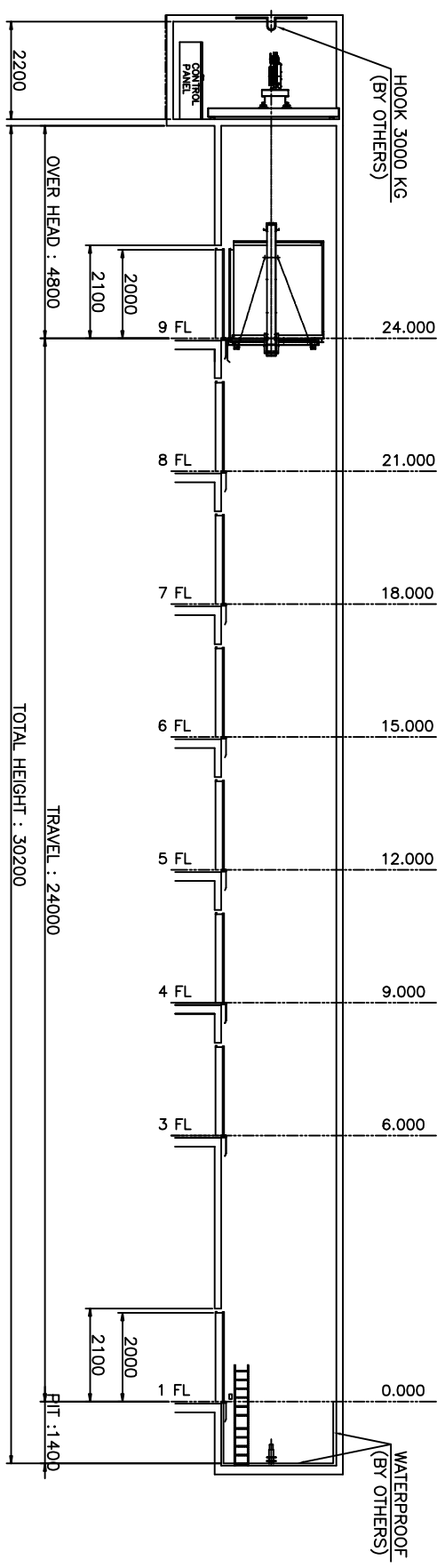
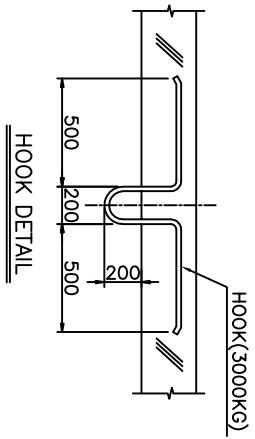

TOTAL HEIGHT	27200
OVER HEAD	4800
TRAVEL	24000
PIT DEEP	1400
FL. HEIGHT	TYPE
1	0.000
3	6.000
4	9.000
5	12.000
6	15.000
7	18.000
8	21.000
8	24.000

APPROVED

Name & Sign: _____

Date: _____

REV MARK	DATE	APPROVED BY	REVISIED BY	CONTENTS

REVISIONS			
3RD ANGLE PROJECTION	SCALE	UNITS	DATE
	N	M/M	2012.04.02
DRAWN BY	DESIGNED BY	CHECKED BY	APPROVED BY
S.M Park	S.M Park	T.H Hwang	T.H Hwang

BUILDING NAME: ZK in 64 kvartal

LOCATION: _____

ECLIPSE

TITLE: HOISTWAY SECTION

DRAWING NO: 4173/78 - E02

REV MARK: _____

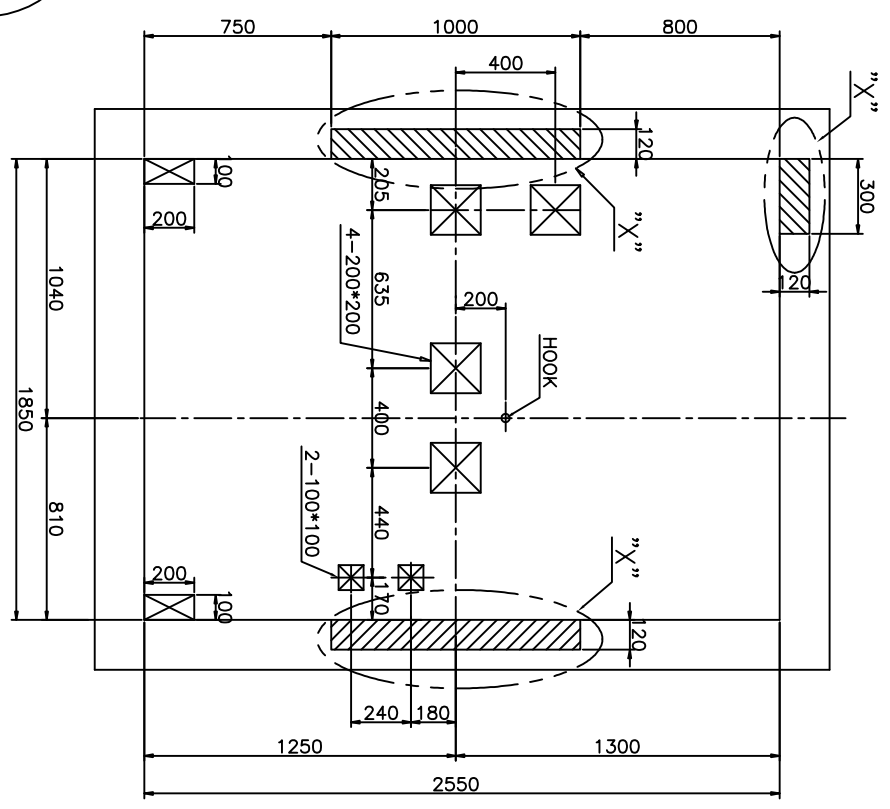
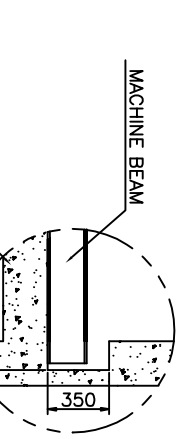
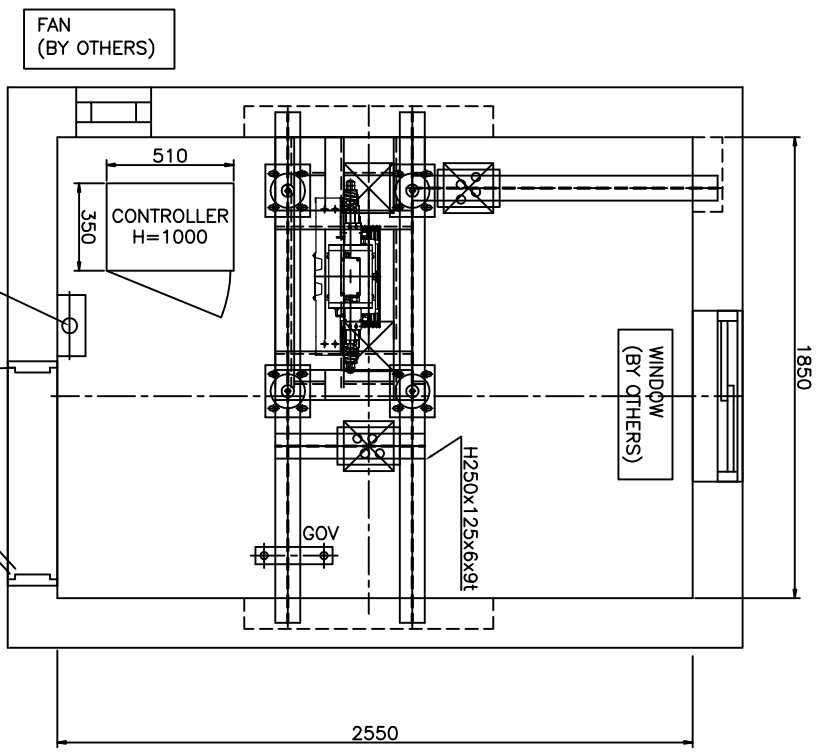

APPROVED

Name & Sign: _____

Date: _____

REV MARK	DATE	CONTENTS

REVISIONS		3RD ANGLE PROJECTION	SCALE	UNITS	DATE
			N	M/M	2012.04.02

BUILDING NAME	LOCATION
ZK in 64 kvartol	

TITLE	DRAWING NO	REV MARK
MACHINE ROOM PLAN	4173/78 - E03	

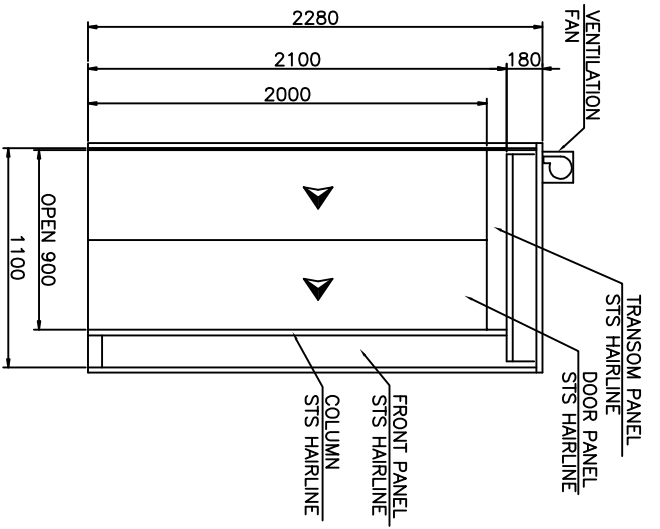

FRONT VIEW OF CABIN

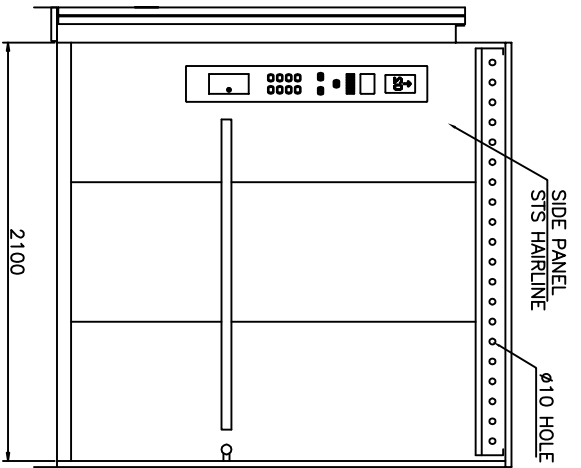

SIDE VIEW OF CABIN

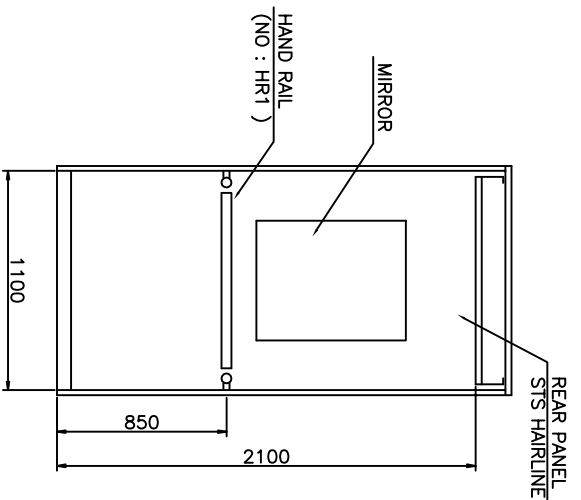

REAR VIEW OF CABIN

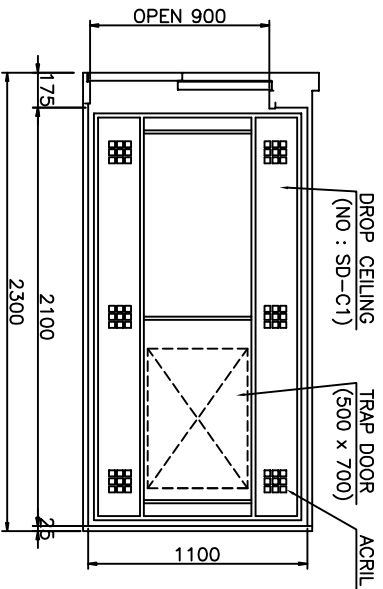

CEILING VIEW

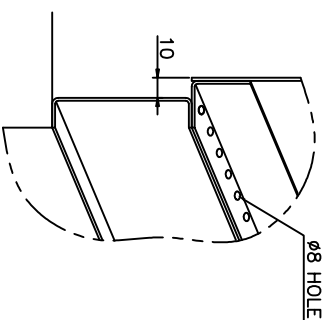

APPROVED	
Name & Sign:	
Date:	

REV MARK	DATE	CONTENTS
APPROVED BY		
REVISED BY		

REVISIONS			
3RD ANGLE PROJECTION	SCALE	UNITS	DATE
N	N	M/M	2012.04.02
DRAWN BY	DESIGNED BY	CHECKED BY	APPROVED BY
S.M Park	S.M Park	T.H Hwang	T.H Hwang

BUILDING NAME	ZK in 64 kvartol
LOCATION	

TITLE	CAR DESIGN
DRAWING NO	4173/78 - E04
REV MARK	

신기술인용 New Technology 신기술인용 우수품질인용 Excellent Quality

130 9001 130 14001

Eclipse ECLIPSE

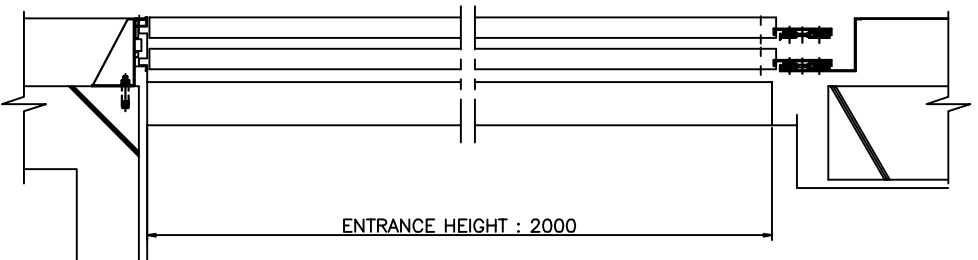

SECTION OF ENTRANCE

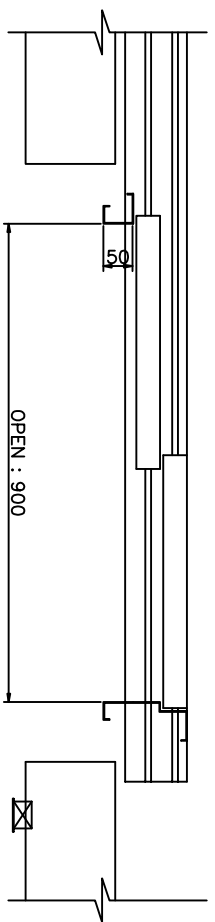

PLAN OF ENTRANCE

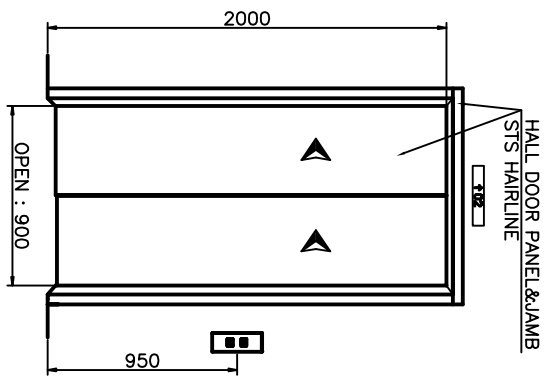

FLOOR 1F

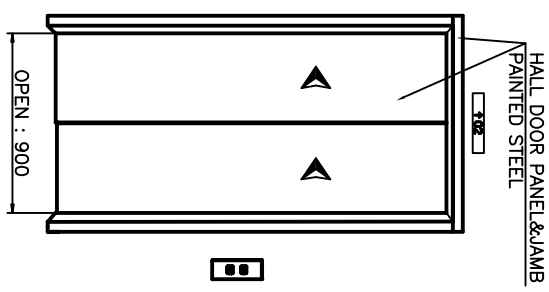

FLOOR 3~9F

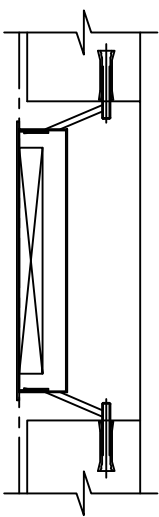

DETAIL OF INDICATOR

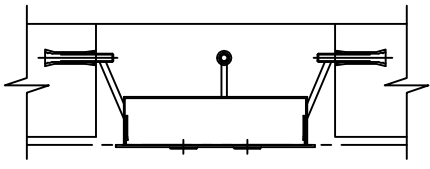

DETAIL OF HALL BUTTON

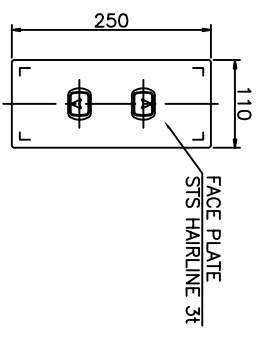

FACE PLATE STS HAIRLINE 3F

APPROVED	
Name & Sign:	
Date :	

REV MARK	DATE	REVISED BY	CONTENTS

REVISIONS			
3RD ANGLE PROJECTION	SCALE	UNITS	DATE
	N	M/M	2012.04.02
DRAWN BY	DESIGNED BY	CHECKED BY	APPROVED BY
S.M Park	S.M Park	T.H Hwang	T.H Hwang

BUILDING NAME	ZK in 64 kvartol
LOCATION	

TITLE	ENTRANCE DESIGN
DRAWING NO	4173/78 - E05
REV MARK	



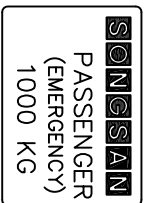
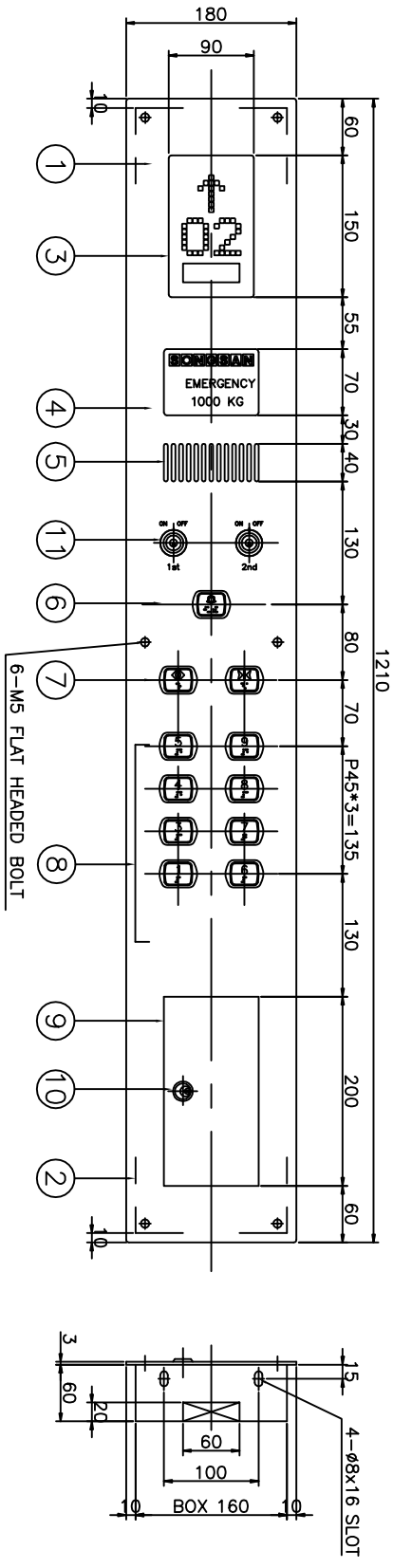

NO	NAME	DESCRIPTION
1	FACE PLATE	STAINLESS STEEL HAIRLINE FINISH (3X)
2	BOX	GALVANIZED SHEET STEEL FINISH
3	L.E.D. DISPLAY AREA	SMOKE ACRYL INCLUDING DIRECTIONAL ARROW & DIGITAL INDICATOR
4	NAME PLATE	BLACK LETTER ETCHING FINISH
5	INTERPHONE HOLE	REAR PUNCHING PLATE
6	INTERPHONE CALL BUTTON	MICRO PUSH BUTTON
7	DOOR OPEN & CLOSE BUTTON	MICRO PUSH BUTTON
8	FLOOR PUSH BUTTON	MICRO PUSH BUTTON
9	SWITCH BOX	INCLUDING : E/STOP-NOR.FANLIGHT-ATT-AUTO.UP-DOWN SWITCH
10	BOX KEY	KEY TYPE
11	FIRE SWITCH 1st AND 2nd KEY	KEY TYPE

APPROVED

Name & Sign: _____

Date: _____

REV MARK	DATE	APPROVED BY	REVISOR BY	CONTENTS

REVISIONS			
3RD ANGLE PROJECTION	SCALE	UNITS	DATE
	N	M/M	2012.04.02
DRAWN BY	DESIGNED BY	CHECKED BY	APPROVED BY
S.M Park	S.M Park	T.H Hwang	T.H Hwang

BUILDING NAME	ZK in 64 kvortol
LOCATION	

TITLE	CAR OPERATING PANEL
DRAWING NO.	SE 4173/78 - E06
REV MARK	

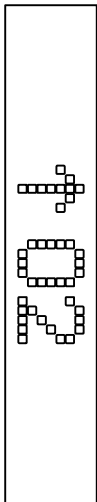

HALL INDICATOR
(1~9FL)

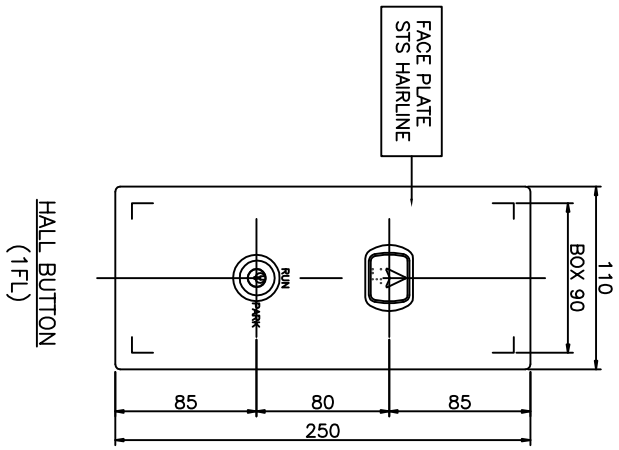

HALL BUTTON
(1FL)

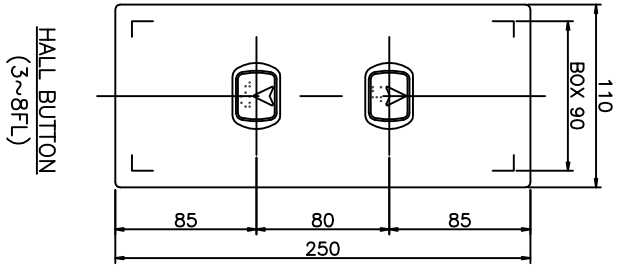

HALL BUTTON
(3~8FL)

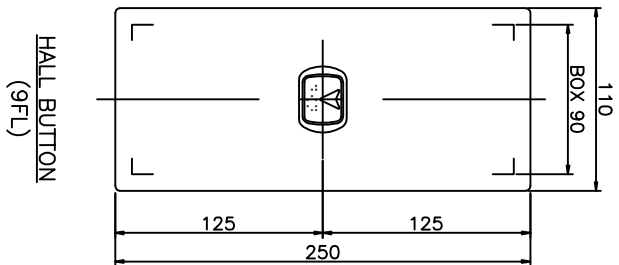

HALL BUTTON
(9FL)

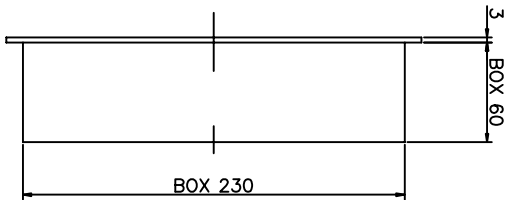

APPROVED	
Name & Sign:	
Date:	

REV MARK	
DATE	
APPROVED BY	
REVISED BY	
CONTENTS	

REVISIONS			
3RD ANGLE PROJECTION	SCALE	UNITS	DATE
DRAWN BY	DESIGNED BY	CHECKED BY	APPROVED BY
S.M Park	S.M Park	T.H Hwang	T.H Hwang
신기술인용 New Technology		우수품질인용 Excellent Quality	
130 9001		130 14001	

BUILDING NAME	ZK in 64 kvartol
LOCATION	
ECLIPSE	

TITLE	HALL BUTTON
DRAWING NO.	SE 4173/78 - E07
REV MARK	