

SPECIFICATION AND DATA

| | | | |
|------------------------|--|------------------------|-------------|
| PROJECT NAME | Voykova, Sochi | | |
| ELEVATOR NO. | NO. 4 | | |
| DESCRIPTION | MP1000-2S1.0M/S-18E/18F | | |
| TYPE OF ELEVATOR | PASSENGER | | |
| CAPACITY | 1000 kg | | |
| RATED SPEED | 1.0 M/Sec | | |
| CONTROL | AC-VVVF, GROUP CONTROL | | |
| OPERATION | SIMPLEX SELECTIVE COLLECTIVE AUTOMATIC | | |
| ENT. / FLOOR | 18 ENT. / 18 FLOOR | | |
| FLOOR MARK | 1~18 FLS | | |
| TRAVEL | 52500 mm | | |
| CAR INSIDE | WIDTH 1100 | DEPTH 2100 | HEIGHT 2100 |
| ENTRANCE | WIDTH 900 | HEIGHT 2000 | |
| LANDING DOOR | 2 PANEL SIDE OPENING | | |
| WIRE ROPE | Ø10 8xS(19) 5 NOS. | | |
| CAR FLOORING | DECO TILE | | |
| CAR RAIL | 8 kg/m | | |
| CWT RAIL | 3U kg/m | | |
| CAR BUFFER | OIL BUFFER | | |
| CWT BUFFER | OIL BUFFER | | |
| MOTOR CAPACITY | 6.2 Kw | | |
| POWER SUPPLY | MAIN | 3 PHASE 380 VOLT 50 Hz | |
| | LIGHT | 1 PHASE 220 VOLT 50 Hz | |
| HOISTWAY INSIDE | | | |
| W | 2100 mm | | |
| D | 2600 mm | | |
| PIT | 1400 mm | | |
| OH | 3700 mm | | |

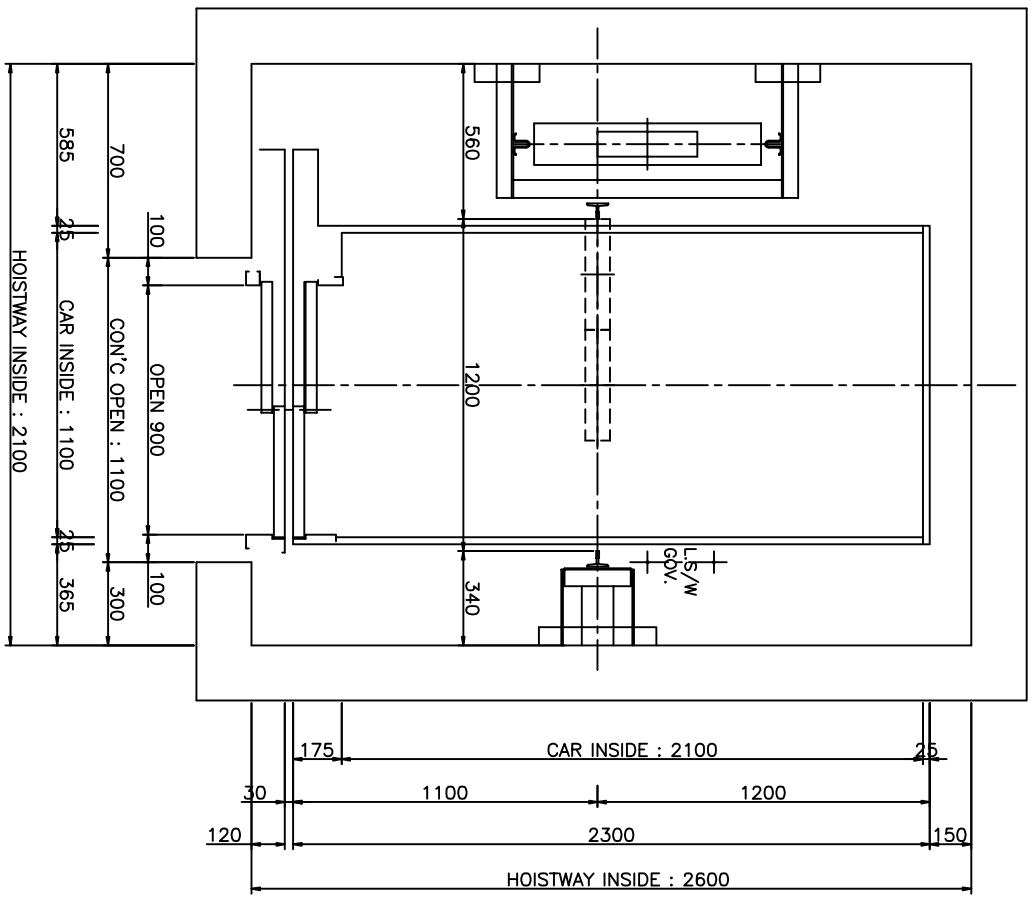

GROUP CONTROL (FOR TWO ELEVATORS)

APPROVED

Name & Sign: _____

Date: _____

| REV MARK | DATE | REVISIONS |
|----------|------|-----------|
| | | |
| | | |
| | | |
| | | |

| 3RD ANGLE PROJECTION | SCALE | UNITS | DATE |
|----------------------|-------------|------------|-------------|
| N | N | M/M | 2012.05.24 |
| DRAWN BY | DESIGNED BY | CHECKED BY | APPROVED BY |
| S.M Park | S.M Park | T.H Hwang | T.H Hwang |

BUILDING NAME

Voykova, Sochi

LOCATION

ECLIPSE

DRAWING NO. SE 0004 - E01

REV MARK

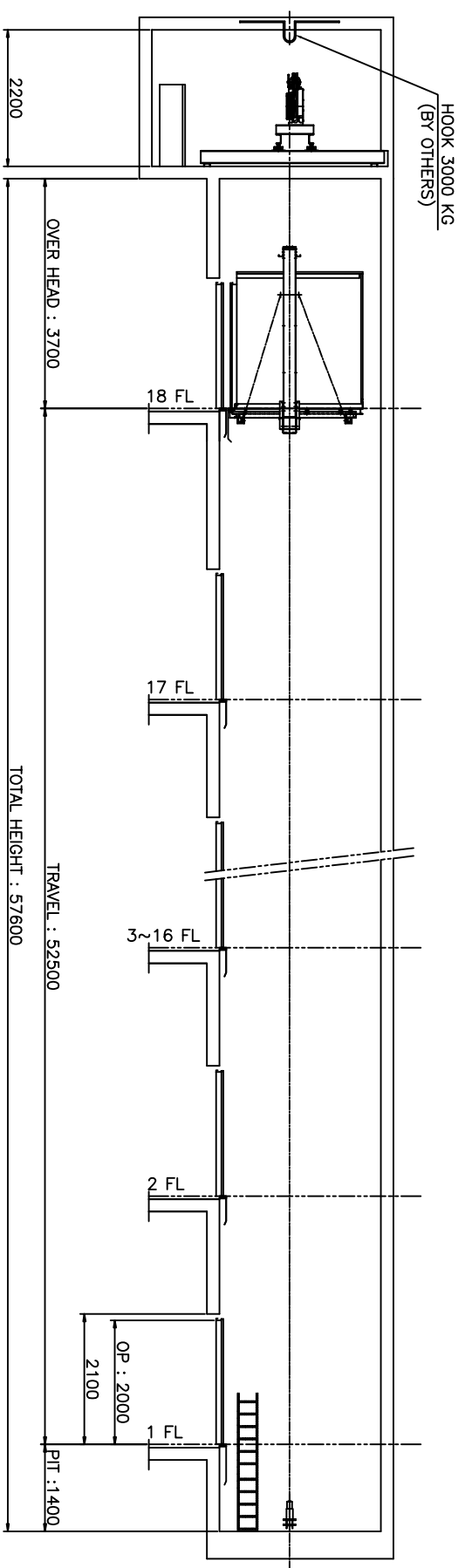
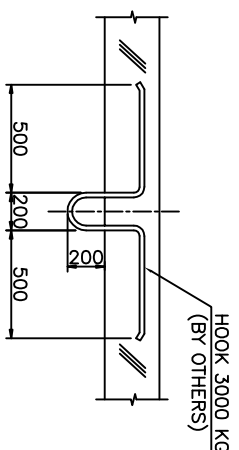

RAIL BRACKET PITCH 1.5M

| FL. HEIGHT | TYPE |
|--------------|-------|
| 1 | |
| 2 | |
| 3 | |
| 4 | |
| 5 | |
| 6 | |
| 7 | |
| 8 | |
| 9 | |
| 10 | |
| 11 | |
| 12 | |
| 13 | |
| 14 | |
| 15 | |
| 16 | |
| 17 | |
| 18 | |
| TOTAL HEIGHT | 57600 |
| OVER HEAD | 3700 |
| TRAVEL | 52500 |
| PIT DEEP | 1400 |

APPROVED

Name & Sign: _____

Date: _____

| REV MARK | DATE | APPROVED BY | REVISIED BY | CONTENTS |
|----------|------|-------------|-------------|----------|
| | | | | |

| REVISIONS | | | |
|----------------------|-------------|------------|-------------|
| 3RD ANGLE PROJECTION | SCALE | UNITS | DATE |
| | N | M/M | 2012.05.24 |
| DRAWN BY | DESIGNED BY | CHECKED BY | APPROVED BY |
| S.M Park | S.M Park | T.H Hwang | T.H Hwang |

Building Name: **Voykova, Sochi**

Location: _____

ECLIPSE

TITLE: **HOISTWAY SECTION**

DRAWING NO. **SE 0004 - E02**

REV MARK: _____

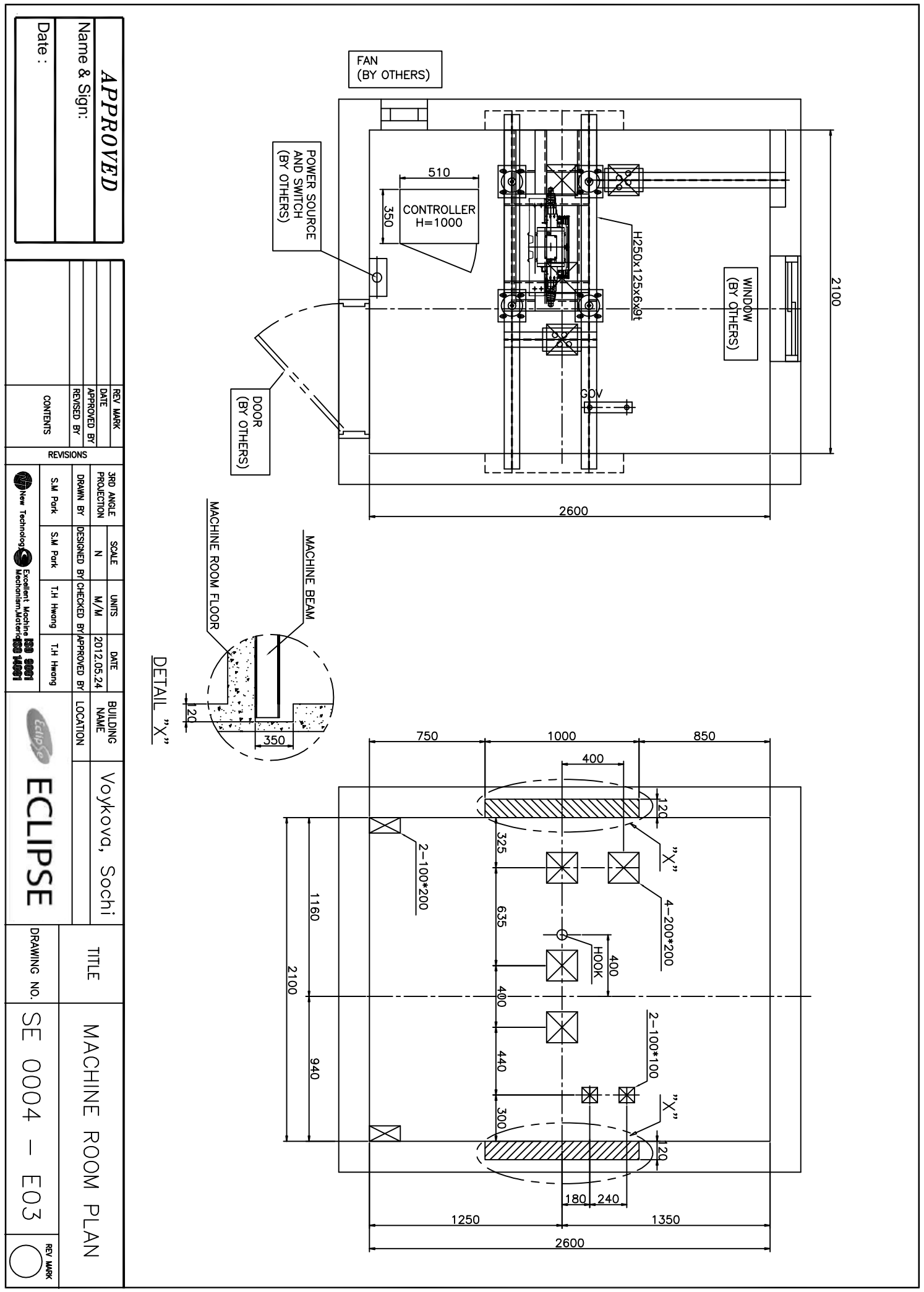

APPROVED

Name & Sign: _____

Date: _____

| REV MARK | DATE | APPROVED BY | REVISIONS |
|----------|------|-------------|-----------|
| | | | |
| | | | |
| | | | |
| | | | |

| 3RD ANGLE PROJECTION | SCALE | UNITS | DATE |
|----------------------|-------|-------|------------|
| | N | M/M | 2012.05.24 |

| DRAWN BY | DESIGNED BY | CHECKED BY | APPROVED BY |
|----------|-------------|------------|-------------|
| S.M Park | S.M Park | T.H. Hwang | T.H. Hwang |

Building Name: **Voykova, Sochi**

Location: _____

Title: **MACHINE ROOM PLAN**

Drawing No.: **SE 0004 - E03**

Rev Mark: _____

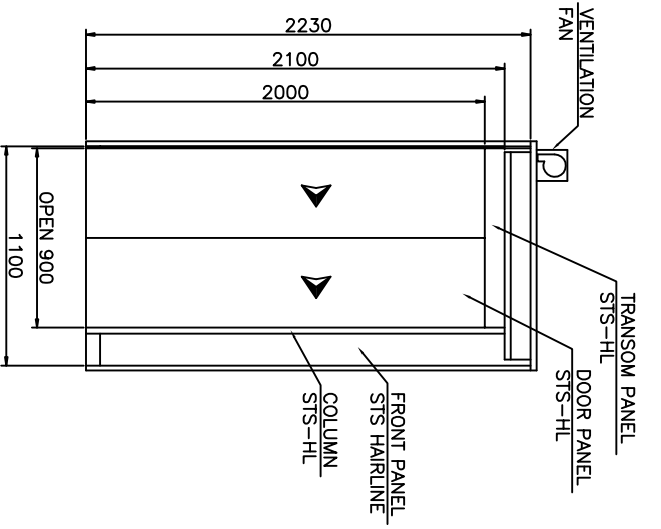

FRONT VIEW OF CABIN

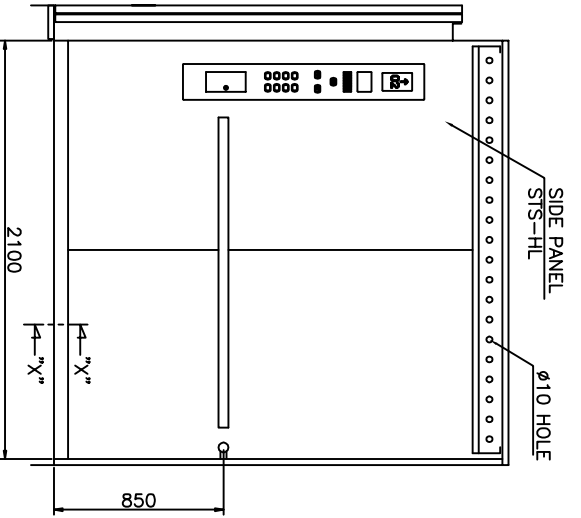

SIDE VIEW OF CABIN

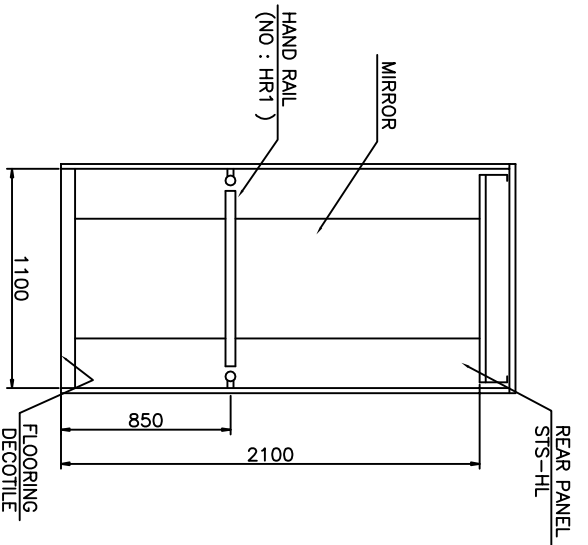

REAR VIEW OF CABIN

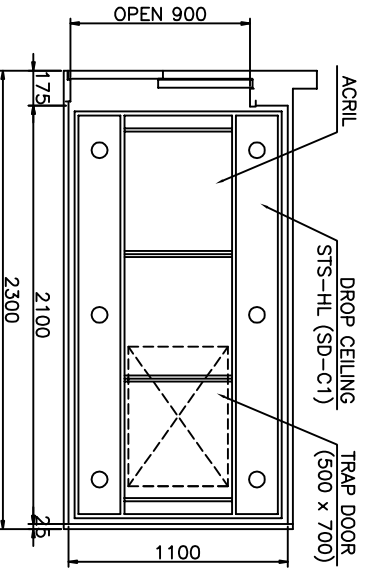

CEILING VIEW

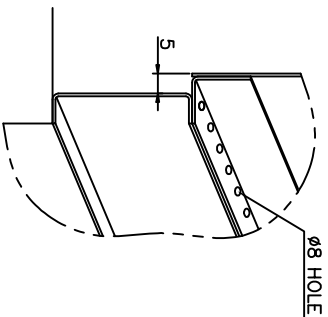

SECTION X-X

| |
|-----------------|
| APPROVED |
| Name & Sign: |
| Date : |

| | | |
|----------|------|-------------|
| REV MARK | DATE | APPROVED BY |
| | | |
| CONTENTS | | |

| REVISIONS | |
|----------------------|-----------------------|
| 3RD ANGLE PROJECTION | SCALE N |
| DRAWN BY S.M Park | DESIGNED BY S.M Park |
| CHECKED BY T.H Hwong | APPROVED BY T.H Hwong |

| | |
|---------------|----------------|
| BUILDING NAME | Voykova, Sochi |
| LOCATION | |

| | |
|-------------|---------------|
| TITLE | CAR DESIGN |
| DRAWING NO. | SE 0004 - E04 |
| REV MARK | |

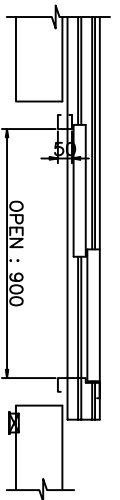

PLAN OF ENTRANCE

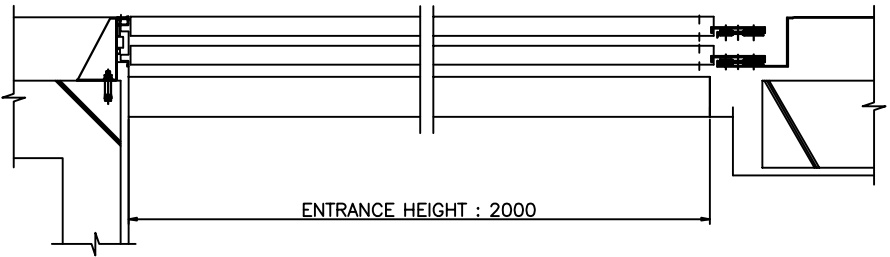

SECTION OF ENTRANCE

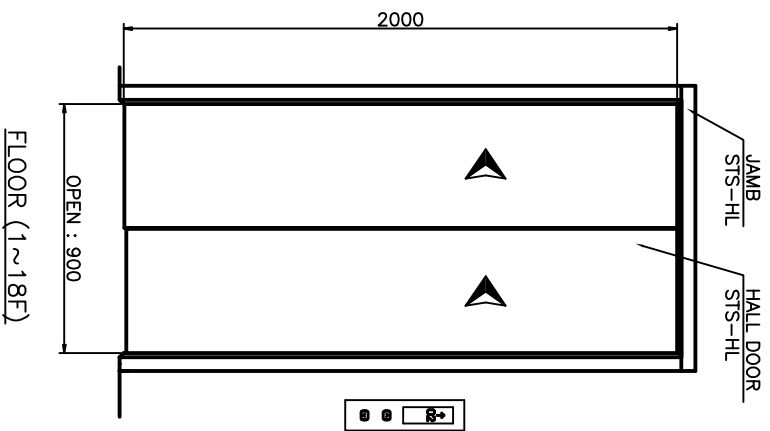

FLOOR (1~18F)

| | |
|-----------------|--|
| APPROVED | |
| Name & Sign: | |
| Date : | |

| | |
|-------------|--|
| REV MARK | |
| DATE | |
| APPROVED BY | |
| REVISED BY | |
| CONTENTS | |

| REVISIONS | | | |
|----------------------|-------------|------------|-------------|
| 3RD ANGLE PROJECTION | SCALE | UNITS | DATE |
| | N | M/M | 2012.05.24 |
| DRAWN BY | DESIGNED BY | CHECKED BY | APPROVED BY |
| S.M Park | S.M Park | T.H Hwang | T.H Hwang |

| | |
|---------------|----------------|
| BUILDING NAME | Voykova, Sochi |
| LOCATION | |

| | |
|-------------|-----------------|
| TITLE | ENTRANCE DESIGN |
| DRAWING NO. | SE 0004 - E05 |
| REV MARK | |

New Technology
Excellent Machine
Mechanism, Material
130 8001
130 14001



ECLIPSE

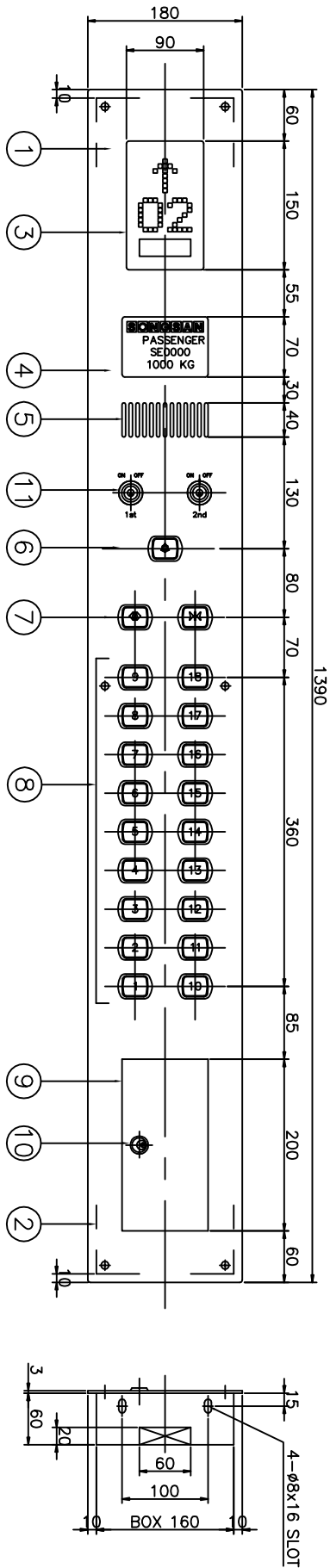

| NO | NAME | DESCRIPTION |
|----|-----------------------------|---|
| 1 | FACE PLATE | STAINLESS STEEL HAIRLINE FINISH (3X) |
| 2 | BOX | GALVANIZED SHEET STEEL FINISH |
| 3 | L.E.D. DISPLAY AREA | SMOKE ACRYL INCLUDING DIRECTIONAL ARROW & DIGITAL INDICATOR |
| 4 | NAME PLATE | BLACK LETTER ETCHING FINISH |
| 5 | INTERPHONE HOLE | REAR PUNCHING PLATE |
| 6 | INTERPHONE CALL BUTTON | MICRO PUSH BUTTON |
| 7 | DOOR OPEN & CLOSE BUTTON | MICRO PUSH BUTTON |
| 8 | FLOOR PUSH BUTTON | MICRO PUSH BUTTON |
| 9 | SWITCH BOX | INCLUDING : E/STOP-NOR.FANLIGHT-ATT-AUTO.UP-DOWN SWITCH |
| 10 | BOX KEY | KEY TYPE |
| 11 | FIRE SWITCH 1st AND 2nd KEY | KEY TYPE |

APPROVED

Name & Sign: _____

Date: _____

| REV MARK | DATE | APPROVED BY | REVISOR | CONTENTS |
|----------|------|-------------|---------|----------|
| | | | | |

| REVISIONS | | | |
|----------------------|-------|-------|------------|
| 3RD ANGLE PROJECTION | SCALE | UNITS | DATE |
| | N | M/M | 2012.05.24 |
| | | | |

| DESIGNED BY | CHECKED BY | APPROVED BY | BUILDING NAME | LOCATION |
|-------------|------------|-------------|----------------|----------|
| S.M Park | S.M Park | T.H Hwang | Voykova, Sochi | |

| TITLE | DRAWING NO. | REV MARK |
|---------------------|---------------|----------|
| CAR OPERATING PANEL | SE 0004 - E06 | |

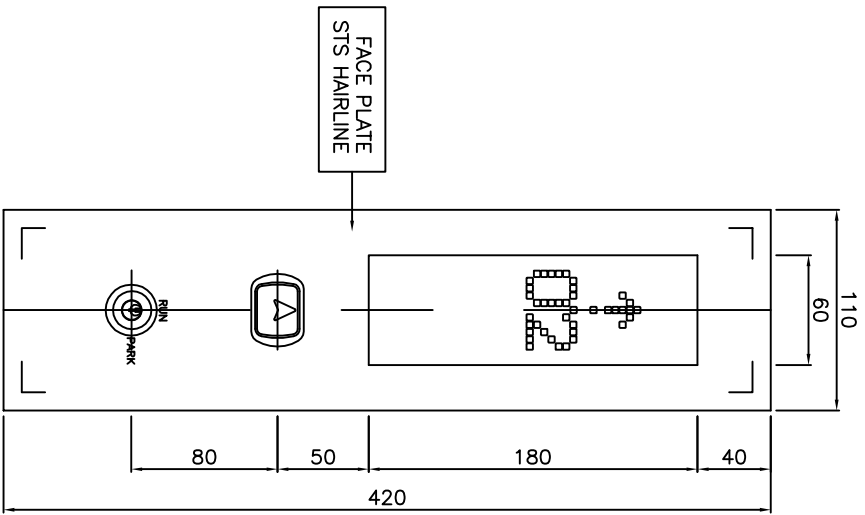

1F

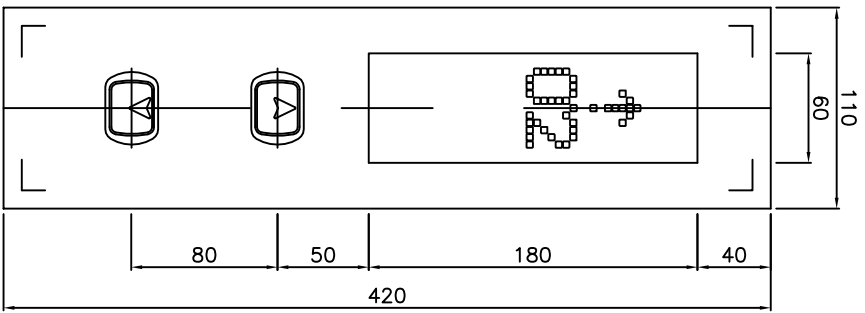

2~17F

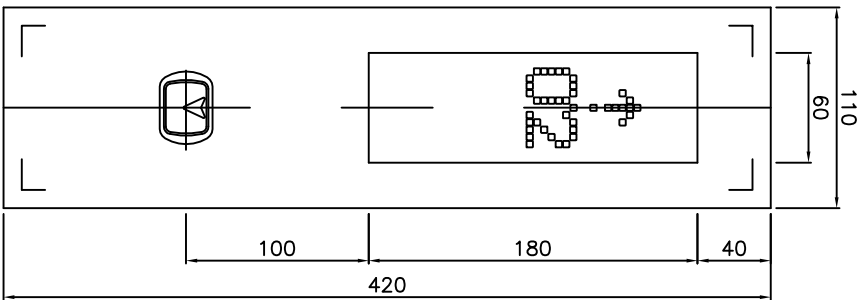

18F

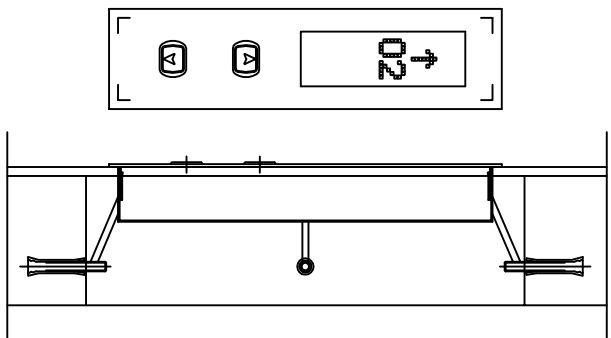
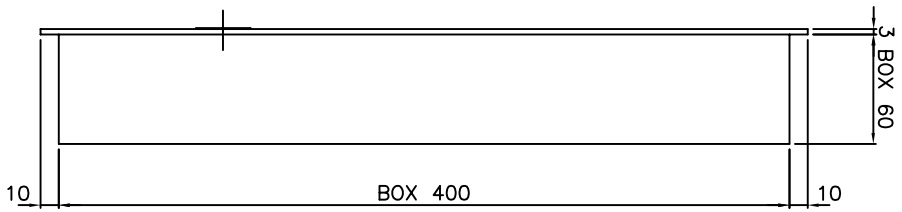

APPROVED

Name & Sign: _____

Date: _____

| |
|--|
| |
| |
| |
| |

| |
|-------------|
| REV MARK |
| DATE |
| APPROVED BY |
| REVISED BY |
| CONTENTS |

| REVISIONS | | | |
|----------------------|-------------|------------|-------------|
| 3RD ANGLE PROJECTION | SCALE | UNITS | DATE |
| | N | M/M | 2012.05.24 |
| DRAWN BY | DESIGNED BY | CHECKED BY | APPROVED BY |
| S.M Park | S.M Park | T.H Hwang | T.H Hwang |

Building Name: **Voykova, Sochi**

Location: _____

ECLIPSE

TITLE: **HALL BUTTON**

DRAWING NO.: **SE 0004 - E06**

REV MARK: ○